

<b>Table of Contents</b>	<b>Sheet No.</b>
Project Narrative	1
General Provisions	1a
Location Plan	2
Sign Matrix	3
Primary Freestanding Identity	4
Site Address Numbers	5
Major Tenant Identity	6
Tenant Identity at Shops A, B, And C	7
Tenant Identity Details	7a
Tenant Identity Standards for Pads A-E	8
Temporary Banner Standards	9
Tenant Address/Suite Standards	9
Context Images	10

---

## **Vineyard Towne Center**

## Project Narrative

This C-2 retail center is situated at the NW corner of Coombs and Gantzel Roads.

Proposed in 2 phases; Phase I encompasses 75,850 square feet of retail space within 6 interconnected and stand-alone buildings.

Building architecture consists of a rustic palette of brick, raw concrete, engineered steel shapes and stucco, with multiple roof and building forms recognizable within an agrarian style.

## Principal Materials Palette



board-formed concrete

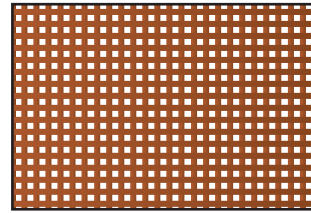

perforated steel



pan channel lettering

## Rendering



## Project Address

37584, 37666, 37724 N Gantzel Road  
200 W Coombs Road  
Queen Creek, AZ 85140

## Proposal

Approval of a comprehensive sign plan that has been developed in keeping with the scale and materiality of the project architecture.

Queen Creek Sign Regulation entitlements have been exceeded in order to provide scale compatibility with the architecture and land mass as well as providing and appropriate visibility to users.

## Proposed Locations

Sign locations are outlined on the site plan - sheet 2.

## Tenant Requirements

Tenant signs are open to individual tenant identities, logos, colors, type, etc, but approval of the design and application method is at the sole discretion of the Owner/Landlord and must be reviewed and approved by such prior to permitting or implementation.

Tenant sign design is to be in harmony with and complimentary to the center's architecture and shall adhere to the details outlined in this document.

Application of tenant identities shall be only as approved by the Owner/Landlord. Any tenant signage installed without written permission by the Owner/Landlord may be removed at the Tenant's expense. Damages may also be assessed for any required repairs as a result of the unauthorized use.

## Landlord Contact Information

Vestar  
2415 E. Camelback Rd.  
Suite 100  
Phoenix, AZ 85016

Contact:

Sally Monzka  
Tenant Coordination Manager

602.553.2650  
smonzka@vestar.com

Implementation of this Comprehensive Sign Plan is subject to Town of Queen Creek approval.

Sign criteria provisions or restrictions not specifically outlined in this document shall follow Town of Queen Creek Zoning Ordinance Article 7.0 Sign Regulations.

## TENANT SIGN CRITERIA

These criteria have been established for the purpose of maintaining a continuity of quality, consistency and aesthetics throughout Vineyard Towne Center for the mutual benefit of all tenants, and to comply with the regulations of Town of Queen Creek sign and electrical codes. Conformance will be strictly enforced, and any installed non-conforming or unapproved signs must be brought into conformance at the sole cost and expense of the Tenant.

### I. GENERAL REQUIREMENTS

- A. Tenant shall submit or cause to be submitted to Landlord, for approval, prior to fabrication, ordering of materials or submittal to Queen Creek for permitting, four (4) copies of to-scale, detailed shop drawings indicating the location, size, layout, design color, pertinent details, illumination, materials, methods of attachment, and engineering calculations of each sign. Landlord may require revisions to the tenant's submitted design to ensure that the signage is in harmony with the center's architecture and complimentary to the overall design intent.
- B. All required permits for signs and their installation shall be obtained by Tenant or Tenant's representative.
- C. All signs shall be constructed and installed at Tenant's sole expense.
- D. Tenant shall be responsible for the fulfillment of all requirements and specifications, including those of the municipality of Queen Creek.
- E. All signs shall be reviewed for conformance with the criteria outlined in this document and overall design quality. Approval or disapproval of sign submittals based on aesthetics of design shall remain the sole right of Landlord or Landlord's authorized representative.
- F. Tenant shall be responsible for the installation and maintenance of Tenant's sign. Should Tenant's sign require maintenance or repair, Landlord shall give Tenant thirty (30) days written notice to effect said maintenance or repair. Should Tenant fail to do the same, Landlord may undertake repairs and Tenant shall reimburse Landlord within ten (10) days from receipt of Landlord's invoice, together with interest thereon at the Default Rate.
- G. Signing for major tenants occupying five thousand square feet (5,000 ft<sup>2</sup>) or more and having a chain store operation with more than five (5) locations will be considered on an individual basis at Landlord's sole discretion.
- H. Signing for tenants of single purpose, free-standing buildings (PAD Tenants) shall be commensurate with the architecture of the building and shall be considered on an individual basis, subject to the approval of Landlord, the Town of Queen Creek and as outlined in the PAD Tenant criteria.
- J. Advertising devices such as attraction boards, posters, banners and flags shall not be permitted.

### II. SPECIFICATIONS – TENANT SIGNS

- A. General Specifications
  1. No animated, flashing or audible signs shall be permitted.
  2. No exposed lamps or tubing shall be permitted.
  3. No neon, backlit canopies, uplighting or flood lights shall be utilized in either signage or for other purposes.
  4. All signs and their installation shall comply with all local building and electrical codes.
  5. No exposed raceways, crossovers or conduit shall be permitted, unless specifically outlined.
  6. All cabinets, conductors, transformers and other equipment shall be concealed.
  7. Painted-on lettering shall not be permitted.
  8. Any damage to the sign band face or roof deck resulting from Tenant's sign installation shall be repaired at Tenant's sole cost.
  9. Upon removal of any sign by Tenant, any damage to the sign band face shall be repaired by Tenant or by Landlord at Tenant's cost.
- B. Location of Signs
  1. All signs or devices advertising an individual use, business or building shall be attached to the building at the location directed by Landlord and as outlined in this document.

### III. DESIGN REQUIREMENTS

Individual illuminated letters will be aluminum pan channel, a minimum of three (3") and maximum of five inches (5") deep. Letter faces will be of acrylic, plexiglas, or polycarbonate as required for conditions, with a min. three-quarter inch ( $\frac{3}{4}$ ") trimcap molding to match for securing the letter face to the letter and applied translucent vinyl for color, if required. Illumination of the letters will be LED modules mounted inside the letters with associated, required equipment, exterior grade, quantity and placement as required for bright and even illumination with no hot spots. LED module lifespan to be a minimum 50,000 hours - 3,000k, 50°C. LED color is to be either white or a color matching the face of the letter. All LED modules and equipment shall be U.L. listed and as required by code.

Letters are to be mounted as described in this document. Aluminum raceways that are to accommodate the wiring and transformers required for illuminating letters that are flush mounted to the building shall be mounted on the inside of the building fascia, so that they are not visible.

#### A. Letter Style or Logo Restrictions

Letter or logo style on the individual illuminated letters for Tenant shall be Tenant's choice, subject to approval of Landlord and/or Landlord's authorized representative.

#### B. Letter Height Restrictions

Height restrictions on individual illuminated letters are as outlined in this document.

### IV. CONSTRUCTION REQUIREMENTS

- A. All exterior signs shall be secured by concealed fasteners, stainless steel, or galvanized as required for conditions.
- B. All signs shall be fabricated using full welded construction and shall be light-tight.
- C. All penetrations of the building structure required for sign installation shall be neatly sealed in a watertight condition; method outlined in shop drawings and subject to Landlord approval.
- D. No labels or other identification shall be permitted on the exposed surface of signs except those required by local ordinance which shall be applied in an inconspicuous location.
- E. Tenant shall be fully responsible for the operations of Tenant's sign contractors and shall indemnify, defend and hold Landlord harmless for, from and against damages or liabilities on account thereof.

### V. MISCELLANEOUS

- A. Tenant shall be responsible for selecting a sign company that carries workers' compensation and commercial general liability insurance against all damage suffered or done to any and all persons and/or property while engaged in the construction or erection of signs with limits of liability satisfying the requirements of Article 9C of the Tenant Lease and Article 6 of the Ground Lease.

**Site Signage**

- A** Primary Freestanding Identity
- B** Site Address Numbers

**Tenant Signage**

- C** Major Tenant Identity under 50,000 sq.ft.
- D** Major Tenant Identity over 50,000 sq.ft.
- E** Tenant Identity at Shops A & B
- F** Tenant Identity at Shops C
- G** Tenant Identity Standards For Pads A-F

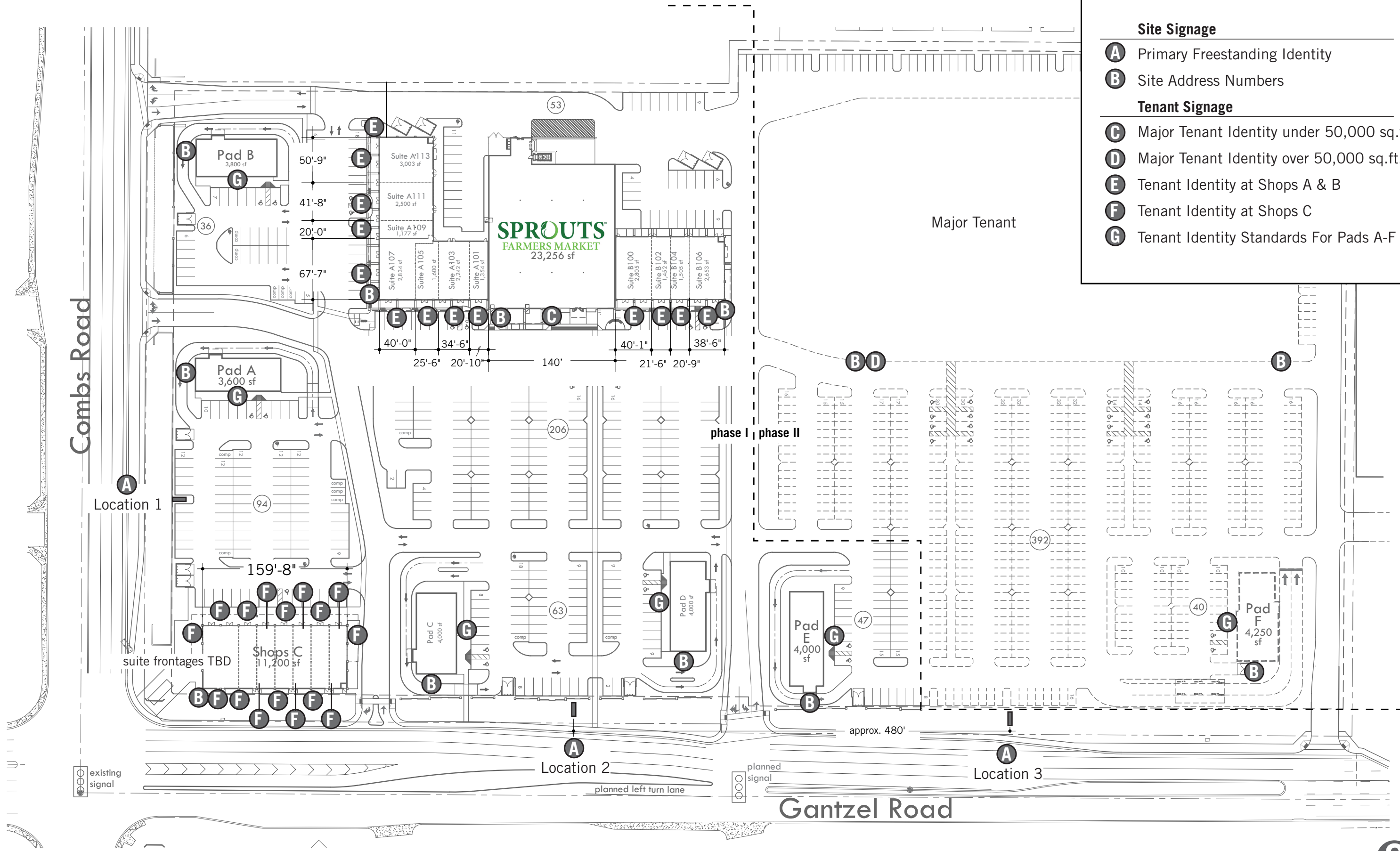

Sign Designation	Description	Maximum Quantity	Maximum Size	Maximum Area	Materials/Fabrication Techniques
<b>A</b>	<b>Primary Project ID</b> Freestanding	3	18' h x 16' l x 4' w	136.5 sq.ft.	Square perforated steel and board-formed concrete support structure paired with applied internally illuminated tenant panels and FCO Project ID letters as outlined on sheet 4.
<b>B</b>	<b>Site Address Numbers</b> Building Mounted	tbd	2' x 8' +-	16+- sq. ft.	Individual reverse pan channel aluminum letters stud mounted to building facade. Non-illuminated
<b>C</b>	<b>Primary Tenant ID under 50,000 sq. ft.</b> Building Mounted	as outlined on sheet 6 for current tenant	as outlined on sheet 6 for current tenant	2 sq. ft. per linear foot of building street frontage and/or elevation on which signage is placed.	Individual pan channel aluminum letters and/or logos with translucent faces, applied digital color (if required), trim caps and internal LED illumination
<b>D</b>	<b>Primary Tenant ID over 50,000 sq. ft.</b> Building Mounted	tbd	tbd	2 sq. ft. per linear foot of building street frontage and/or elevation on which signage is placed	Individual pan channel aluminum letters and/or logos with translucent faces, applied digital color (if required), trim caps and internal LED illumination
<b>E</b>	<b>Secondary Tenant ID Shops A &amp; B</b> Building Mounted	1 per tenant 2 per suite A107 and A113 tenant	30" maximum letter height 80% of tenant frontage width maximum	2 sq. ft. per linear foot of building street frontage and/or elevation on which signage is placed	Individual pan channel aluminum letters and/or logos with translucent faces, applied digital color (if required), trim caps and internal LED illumination mounted onto i-beam structure as outlined in drawings
<b>F</b>	<b>Secondary Tenant ID Shops C</b> Building Mounted	2 per in-line tenants 3 per end tenants	30" maximum letter height 80% of tenant frontage width maximum	Front elevation - 1 1/2 sq. ft. per lineal foot of frontage Side and back elevations 1/2 sq. ft. per linear foot of frontage. Tenant has the option of determining which elevations are to be calculated as front, side and back.	Individual pan channel aluminum letters and/or logos with translucent faces, applied digital color (if required), trim caps and internal LED illumination mounted onto i-beam structure as outlined in drawings
<b>G</b>	<b>Pad Tenants</b> Building Mounted	varies	varies	Front elevation - 1 1/2 sq. ft. per lineal foot of frontage Side and back elevations 1/2 sq. ft. per linear foot of frontage. Tenant has the option of determining which elevations are to be calculated as front, side and back.	Individual pan channel aluminum letters and/or logos with translucent faces, applied digital color (if required), trim caps and internal LED illumination as outlined in drawings
<b>Ga</b>	<b>Pad Tenants menu signs and directionals</b> Freestanding or wall-mounted	varies	as allowed by Queen Creek Sign Regulations	as allowed by Queen Creek Sign Regulations	As required by Queen Creek Sign Regulations and as approved by Landlord. May be internally illuminated.
<b>H</b>	<b>Temporary Banners</b> Window Mounted	1 per tenant	tbd	tbd	Printed, completely removable static-cling vinyl
<b>J</b>	<b>Tenant address-Suite Standards</b> Window Applied		1'-5" x 4'-6"	6.5 sq. ft	Second surface die-cut applied vinyl

sign area measurement methodology shall be as per Queen Creek Zoning Ordinance Article 7.0 Sign Regulations



## NOTES

- 1 Aluminum reverse pan channel letters, painted and stud mounted to building facade. Non-illuminated.

Font is Frutiger Bold

- 2 For Pad tenants, location of address numbers shall occur within upper third of the overall building height, inset from any corner, aligned to an architectural element, and placed on an elevation as required by Town of Queen Creek Fire Code. Paint color to be selected for high contrast to the facade color on which it is to be placed.

Size of address numbers as required by Town of Queen Creek Fire Code.

Location, paint color and configuration of address numbers are to be reviewed and approved by Landlord/Owner and may require modifications prior to approval.



**Square Footage**

16+ sq.ft. Total

**NOTES**

- ① Individual aluminum pan channel letters with translucent faces, digitally printed color and trim caps - mechanically attached to building facade. Colors as per tenant. Illumination is internal LED.
- ② Individual aluminum pan channel letters with translucent faces, digitally printed color and trim caps - mechanically attached to framed backer. Colors as per tenant. Letter illumination is internal LED.

**Total Square Footage**

Primary ID letters	154.1 sq.ft.
Secondary ID panels 4 @ 25.63 sq.ft.	<u>102.5 sq.ft.</u>
	256.6 sq.ft. total

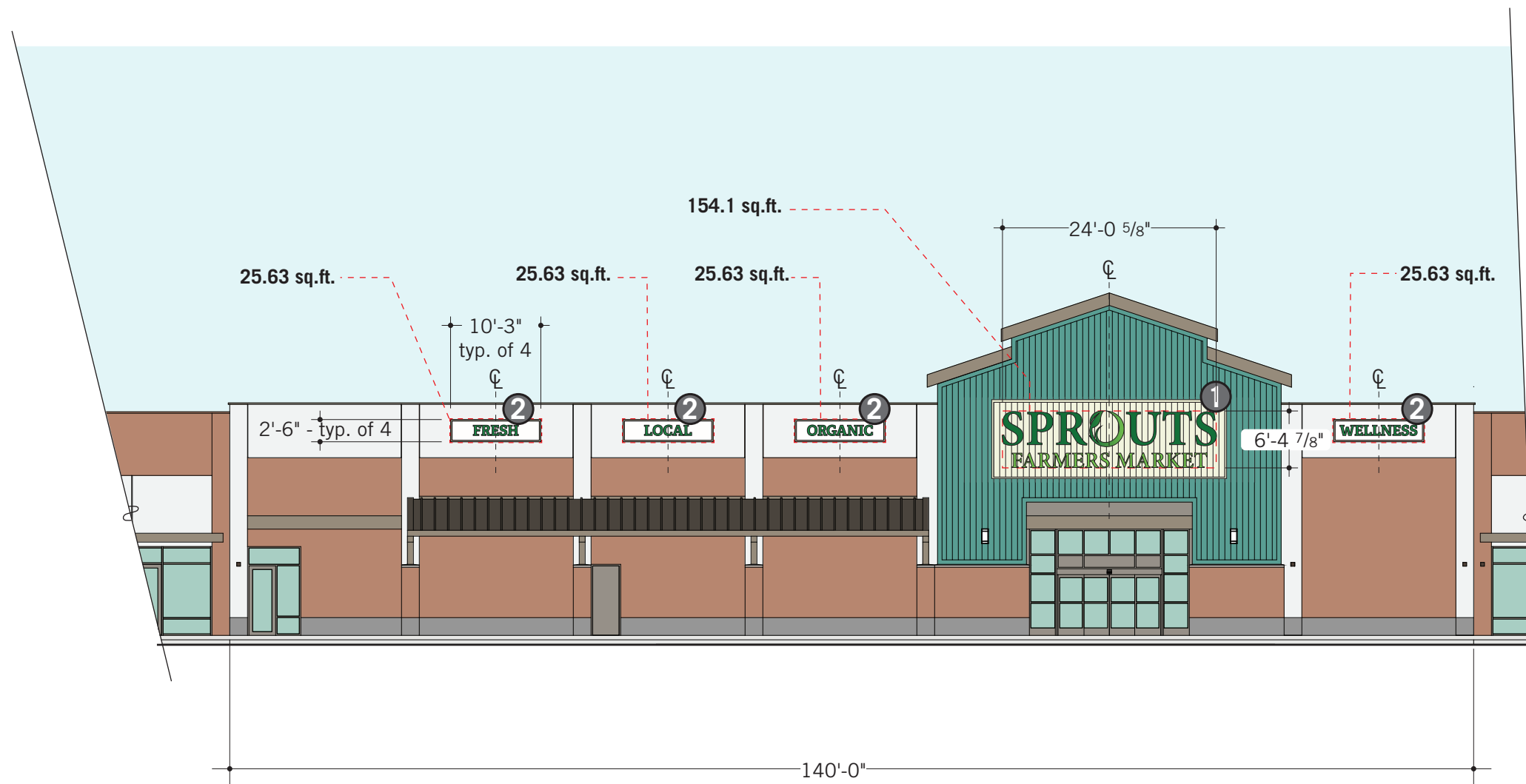



**NOTES**

- ① Existing 6 1/2 x 12 horizontal i-beam.
- ② Aluminum support structure and LED equipment housing mounted to top of i-beam and painted to match.
- ③ Tenant ID - internally LED illuminated fully-welded light-tight individual aluminum pan channel letters and/or logos with corresponding trim cap and translucent faces mounted to front face of structure. See detail, sheet 7a. Letter depth 3" min. to 5" maximum as required for bright and even illumination with no hot spots. Materials, finishes, and fabrication techniques shall be selected for a stable and durable installation and shall be of the highest standard.

Letters/logos may be mounted at the top of the i-beam or at the face.

- ④ All signage element design and shop drawings shall be reviewed and approved by Landlord/Owner prior to tenant submittal for permit or any fabrication.

Proposed application of Tenant identities that deviate from single-line letter configuration will be considered by Landlord on a case-by-case basis.

Approval of tenant sign(s) is at the sole discretion of the Landlord/Owner and tenant's submitted design may require revision to ensure that the signage is in harmony with the the center's architecture and complimentary to the overall design intent.

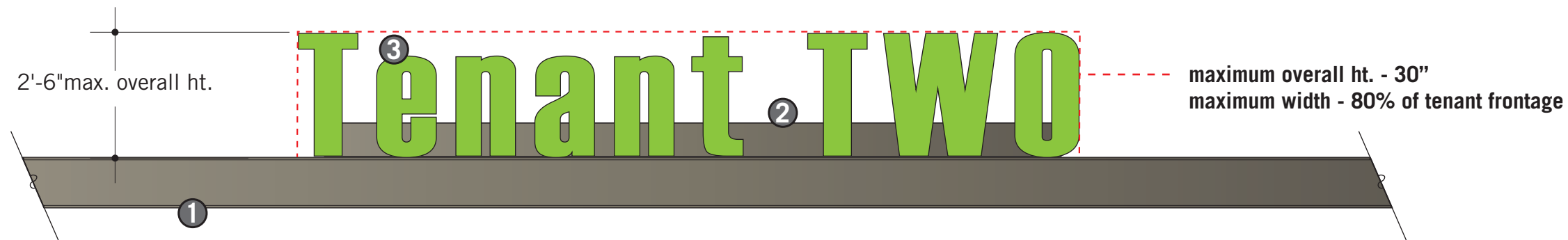

front elevation - top mounted condition

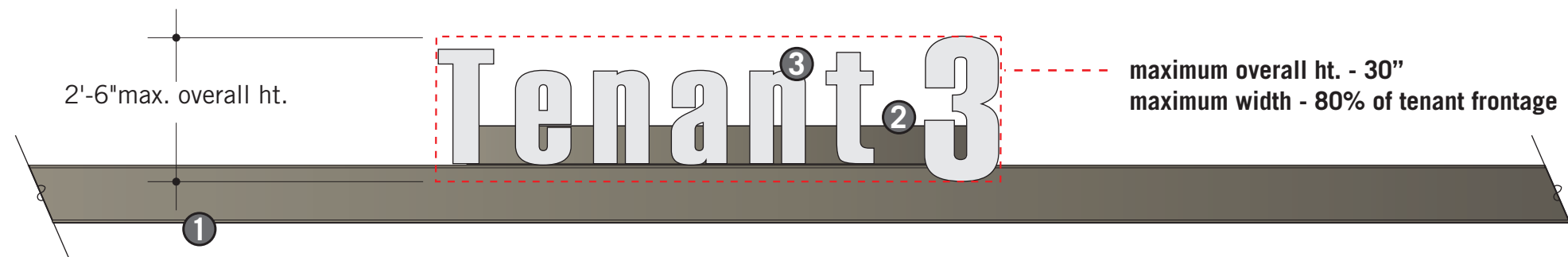

front elevation - face mounted condition

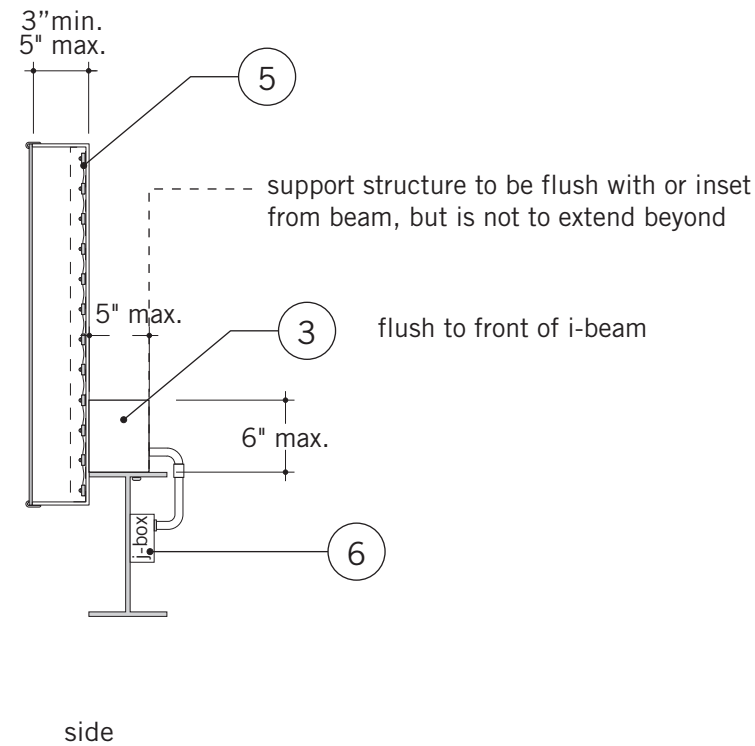
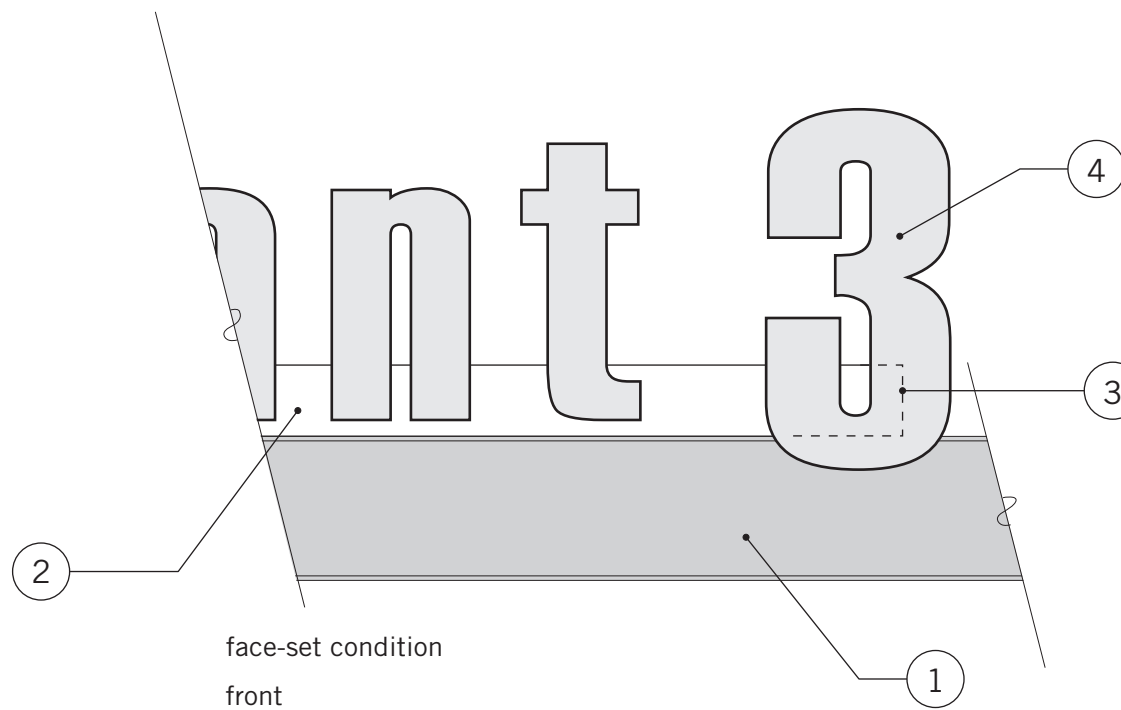
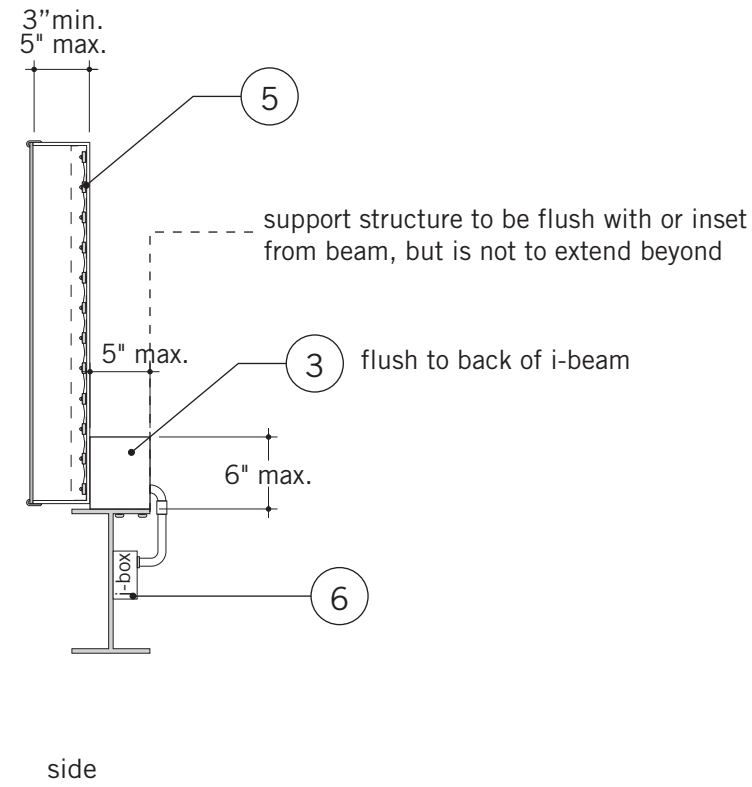
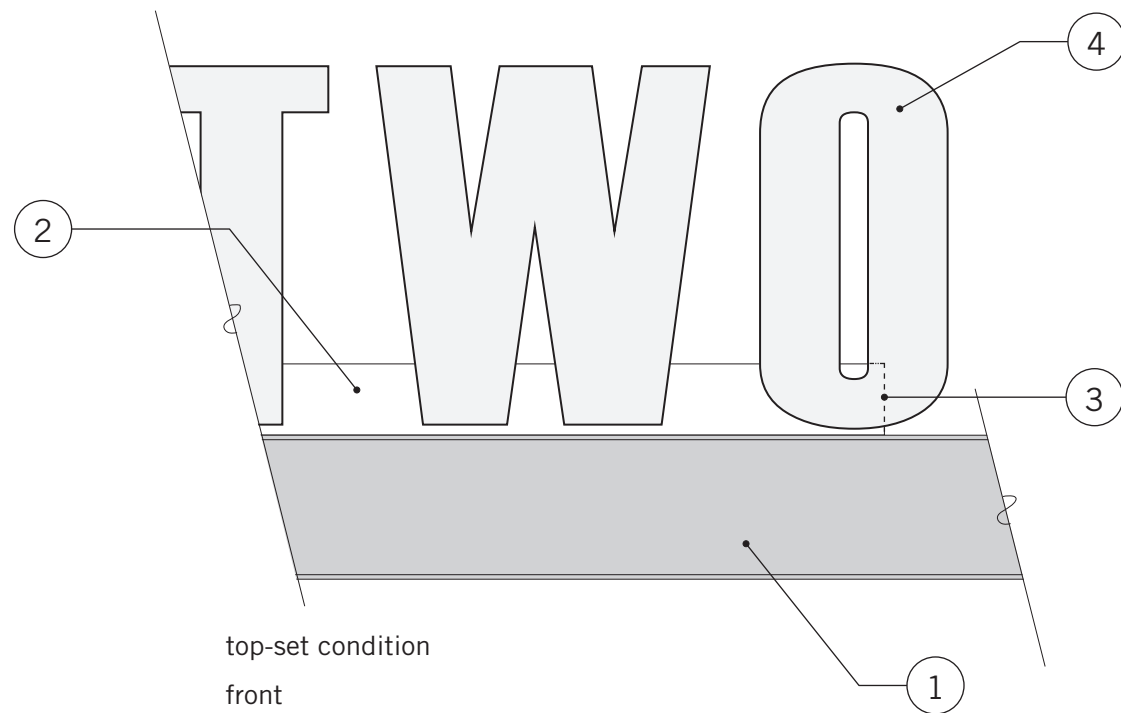

## NOTES

- ① Existing 6 1/2 x 12 horizontal i-beam. Fabricator to field verify dimensions and configuration prior to generating shop drawings. Tenant Identity and support structure to be fabricated and installed so that the finish of the i-beam is not damaged in any way.
- ② Fully welded, painted aluminum support structure and LED wiring/equipment housing. Structure to be fabricated as a finished, visible piece and mechanically attached to i-beam at the back side. Access panel to be located at top of structure, flush with all edges and secured with stainless steel CS fasteners as required. Fasteners that are visible from the front are not allowed. Fabrication of structure and attachments to i-beam as required by engineering. Finish to be Matthews matched to i-beam - Benjamin Moore 1546 "Gargoyle" - satin finish with UV clearcoat; color to be verified with Landlord and outlined in shop drawings.
- ③ Support structure to be inset from each end of Tenant ID as far as is feasible, but equally centered behind the overall width of the identity.
- ④ Fully-welded, painted and UV clear coated, light-tight individual aluminum pan channel letters or logos with corresponding trim cap, translucent faces, and applied vinyl color (if required), mechanically attached to support structure as required. If internal structure is required, it is to be coordinated with LED placement, so that illumination is bright and even. Trim cap size and material thicknesses as required for conditions and as per engineering.
- ⑤ LED lighting, spacing and arrangement for bright and even illumination with no hot spots. Inside of letters/logo to be painted bright white.
- ⑥ 120 v power available at j-box attached to back of i-beam within 15 feet of sign location. Fabricator to extend rigid conduit from j-box to sign location as required, painted to match. All LED equipment, wiring, etc. at sign location to be concealed within lettering/logos and support structure. No flexible conduit, additional exposed conduit or j-boxes will be allowed. Conduit routing to be neat and direct and clearly outlined in the shop drawings.
- ⑦ Tenant's sign fabricator to provide engineered, stamped/sealed shop drawings for Tenant identity and support structure and to ensure that all elements are fabricated for a stable and durable installation while adhering to the aesthetic details indicated. All shop drawings are to be submitted to and reviewed and approved by Landlord/Owner prior to submitting for permit or any fabrication.



illustrative placement example

## NOTES

- 1 Tenant Identity signs shall occur within architectural insets that are repairable in nature and not at brick or metal facades unless otherwise approved by Owner/Landlord.  
  
Square Footage entitlements are as outlined in matrix, sheet 3.
- 2 All signs shall be aligned along either the same baseline or centerline and must occur no closer than 4' from any building corner or roofline unless deviations from such are approved by the Landlord/Owner. Placement criteria is subject to modification upon building facade development.
- 3 Signs are to be individual pan channel light-tight aluminum letters or logos with internal steady LED illumination and are to be mechanically attached to building facade as required. Materials and fabrication techniques shall be selected for a stable and durable installation and shall be of the highest standard. See sheet 1a
- 4 All fasteners, connections, conduit, hardware and lighting components are to be completely concealed within the individual letters/logo or housed within the building, if applicable. Exposed raceways are not acceptable unless they are designed as an integral component of the sign composition, are fabricated and finished to the level of a designed element and reviewed and approved by the Landlord/Owner.
- 5 All signage element design and shop drawings shall be reviewed and approved by Landlord/Owner prior to tenant submittal for permit or any fabrication. Approval is at the sole discretion of the Landlord/Owner and tenant's submitted design may require revision to ensure that the signage is in harmony with the the center's architecture and complimentary to the overall design intent.
- 6 Entitlement criteria not outlined herein shall be as per Town of Queen Creek Zoning Ordinance, *Article 7.0 Sign Regulations*

**NOTES**

- 1 Suite numbers and hours of operation in applied white die-cut vinyl - second surface applied. Placement and configuration as shown. Font for suite no. to be Frutiger Black. Lay-out to be reviewed and approved by Landlord/Owner prior to any fabrication or installation.
- 2 Temporary Grand Opening Banner to be second-surface applied static cling printed vinyl as required for temporary use and complete removal and is to encompass entire window panel as shown. Banner is not to be attached to window mullions in any way. Banner design to be submitted to Landlord/Owner for review and approval prior to any fabrication or installation. **A temporary sign permit is required.**

Location of suite nos./ hours and temporary banner can occur on either right or left side of main entry doors.



Grand Opening Banner

Suite No. - Hours of Operation

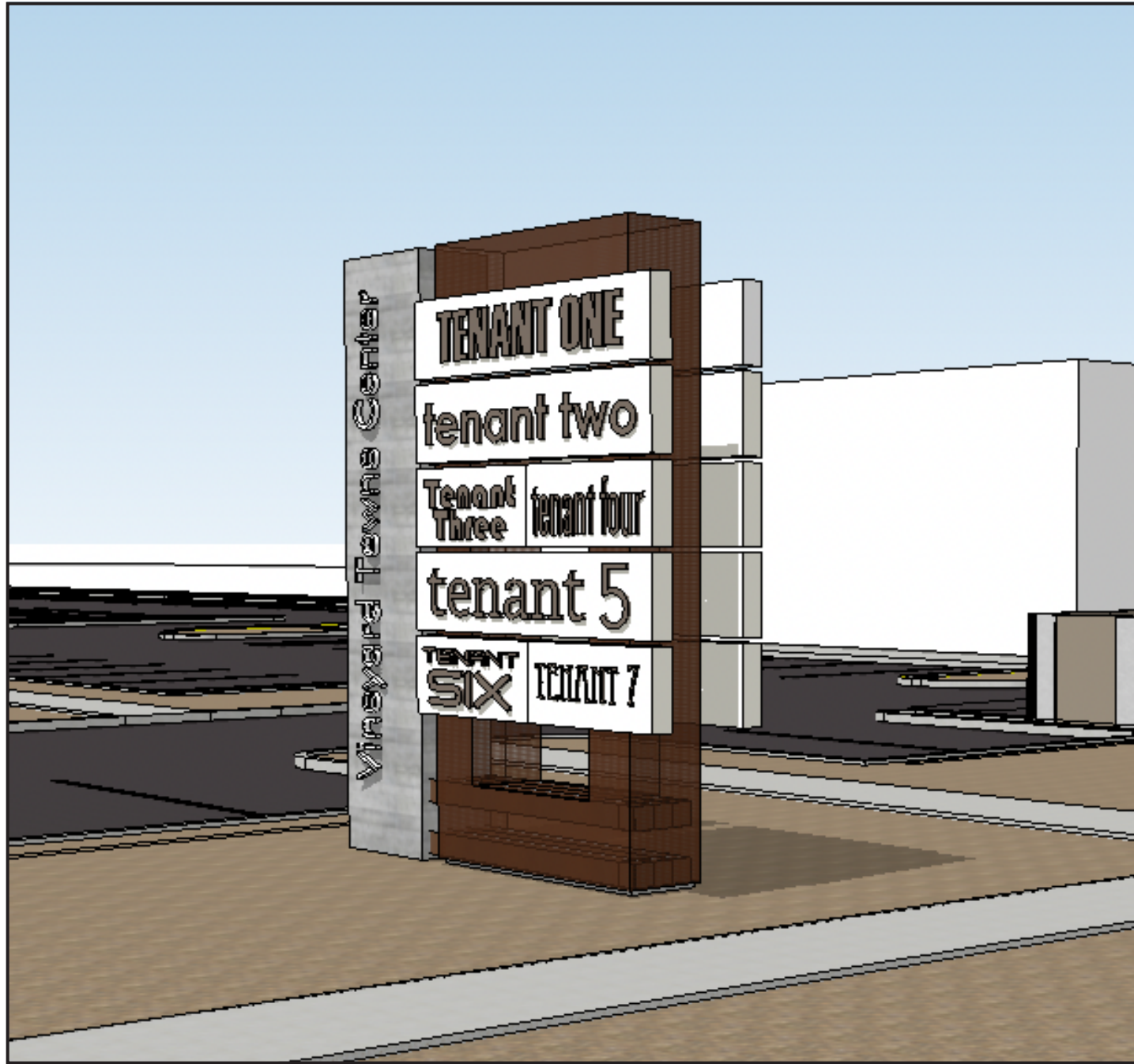

**A** Primary Freestanding Identity



**E** Tenant Identity @ Shops A-C